

# Instructions for Applying Sail Numbers

Class Rule 4 (with 27(e) for Laser Radial and 28(e) for Laser 4.7) require that your sail numbers (and National Letters if used) are a certain size and colour and are placed on the sail in a certain position. National Letters are only required at World and Continental Championships and other events described as international events in their notices of race and sailing instructions. Numbers/letters drawn on the sail with permanent ink pens or similar are illegal.

## Style and Colour

Each number/letter must be upright, solid (not outline), a uniform thickness and easy to read. Each number/letter must be one colour only. All the letters must be the same colour. The last 4 digits of the number must be the same dark colour (preferably black). Any preceding digits must be all red or a single different contrasting colour. The colours must be dense and contrast so that they are easy to read.

## Applying Sail Numbers

1. If your sail has been used it should be sponged clean with mild soap and warm water and allowed to dry completely.
2. Find a clean, large flat working surface (a table or clean hard floor).

## STARBOARD SIDE NUMBERS

3. Spread the sail out flat on the working surface so that the starboard side of the sail is facing up. (To find the starboard side the luff sleeve should be on the RIGHT hand side of the sail when laid flat.)
4. Refer to the instructions below and sail diagrams of the Laser, Laser Radial and Laser 4.7 sail for measuring and drawing pencil Base Lines on the sail and for cutting a template out of cardboard or stiff paper both as a guide for the position of characters, spaces between each character and between rows.
5. Following the instructions below draw a pencil Base Line for the starboard numbers. This Base Line will locate the bottom edge of the starboard numbers.
6. Make a small pencil mark 100 mm from the leech on the Base Line.
7. Place the smaller edge of the template on the line immediately to the left of the pencil mark so that the template is at 90 degrees to the line. This is the starting point for the first number.
8. Peel and fold back 10 mm of backing from the base of the first number. Place the number on the sail against the right hand edge of the template with the base of the number just touching the pencil line.  
Check that the number is lined up with the Base Line and template and press the base of the number on to the sail. Lift the remainder of the number and slowly peel off the backing as you smooth the number on to the sail taking care to remove air bubbles and creases.
9. For the second and subsequent numbers on the starboard side place the template alongside the right hand edge of the previous number to space the next number correctly.

## PORT SIDE NUMBERS

10. Turn the sail over and flatten the sail (the luff sleeve should now be on the LEFT hand side of the sail).
11. Following the instructions below draw a pencil Base Line for the port numbers.
12. Make a small pencil mark 100 mm from the leech on the Base Line.
13. Lay all the numbers on the sail using the spacing template and check that the full number is correct.
14. Apply the number closest to the leech (the last digit in the sail number) first using the base line and the template working away from the leech.

## STARBOARD SIDE LETTERS

15. Turn the sail over and flatten the sail (the luff sleeve should now be on the RIGHT hand side of the sail).
16. Following the instructions below draw a pencil Base Line for the starboard letters.
17. Follow instructions 6 to 9 above.

## PORT SIDE LETTERS

18. Turn the sail over and flatten the sail (the luff sleeve should now be on the LEFT hand side of the sail).
19. Follow instructions 11 to 14 above.

# Laser®

First 2 numbers  
red  
Last 4 numbers  
black

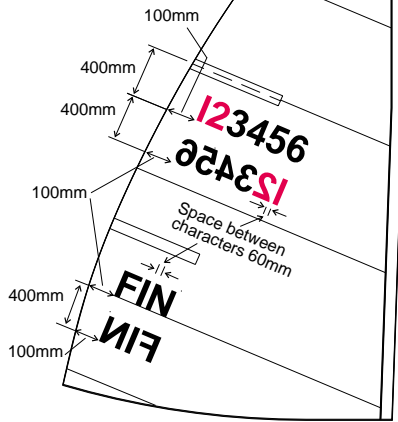

## DRAWING BASE LINES AND MEASUREMENTS

### LASER

Minimum dimensions of numbers/letters: Height 300 mm; Width (excluding No.1 and letter I) 200 mm; Thickness 45 mm. Space between numbers/letters:60 mm.

**Starboard Side Laser Numbers** - Find the middle batten pocket and draw a 1600 mm line parallel to and 400 mm below the seam that runs through the middle batten pocket.

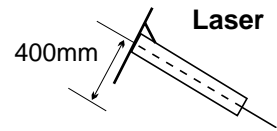

### Port Side Laser Numbers

- draw a 1600 Base line parallel to and 400 mm below the bottom edge of the starboard numbers.

**Starboard Side Laser Letters** - find the seam below the bottom batten pocket. Use the top edge of the seam as the Base Line.

**Port Side Laser Letters** - draw an 820 mm Base Line parallel to and 400 mm below the bottom edge of the starboard side letters.

### LASER RADIAL

Minimum dimensions of numbers/letters: Height 300 mm; Width (excluding No.1 and letter I) 200 mm; Thickness 45 mm. Space between numbers/letters:60 mm.

### Starboard Side Laser Radial Numbers

Find the middle batten pocket and draw a 1600 mm Base Line parallel to and 400 mm below the middle batten pocket.

**Port Side Laser Radial Numbers** - draw a 1600 Base line parallel to and 400 mm below the bottom edge of the starboard numbers.

**Starboard Side Laser Radial Letters** - Measure the height of the letters and draw a 820 mm Base Line parallel to and the height of the letters below the bottom edge of the bottom batten pocket (the top of the letters shall be just below the batten pocket).

**Port Side Laser Radial Letters** - draw a 820 mm Base Line parallel to and 400 mm below the bottom edge of the starboard side letters.

# Laser® Radial

First 2 numbers  
red  
Last 4 numbers  
black

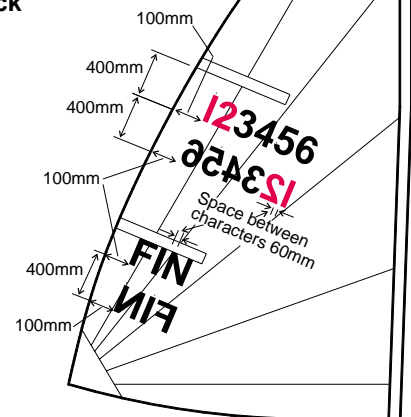

# Laser® 4.7

First 2 numbers  
red  
Last 4 numbers  
black

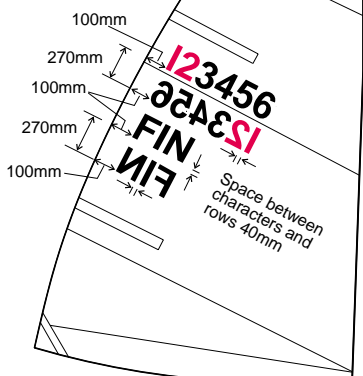

### LASER 4.7

Minimum dimensions of numbers: Height 220 mm; Width (excluding No.1/letter I) 150 mm; Thickness 30 mm. Space between numbers/letters and rows 40 mm.

**Starboard Side 4.7 Numbers** - find the seam below the middle batten pocket. Use the top edge of the seam as the Base Line.

**Port Side 4.7 Numbers** - draw a 1080 mm Base Line parallel to and 270 mm below the bottom edge of the starboard side numbers.

**Starboard Side 4.7 Letters** - draw a 650 mm Base Line parallel to and 270 mm below the bottom edge of the port side numbers.

**Port Side 4.7 Letters** - draw a 650 mm Base Line parallel to and 270 mm below the bottom edge of the starboard side letters.